

System Features

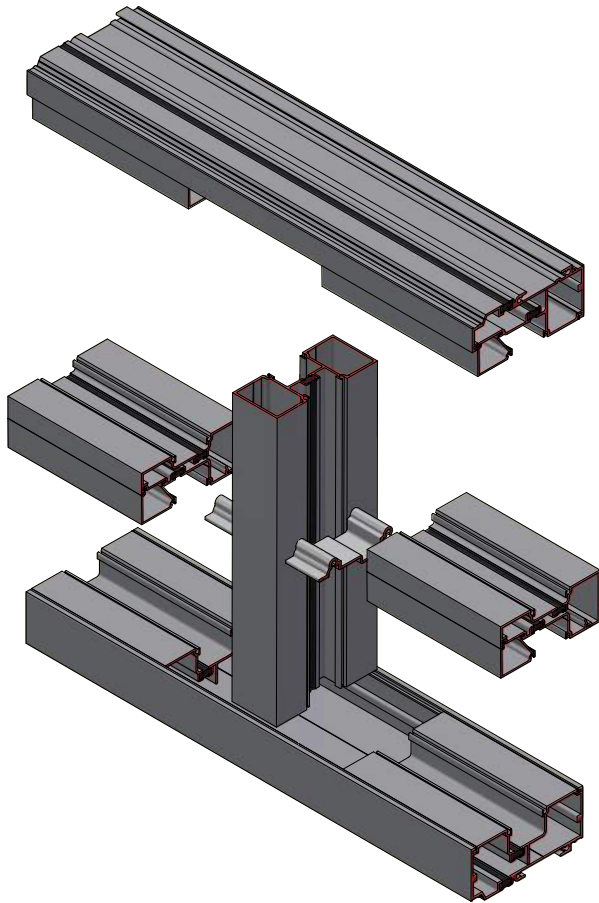

Facades USA's 1500T Storefront System is an easy to install stick built system featuring options to meet the needs of most projects.

- Mullion Styles:
 - 4-Sided Captured
- System Dimensions:
 - 2" Sightlines
 - 4-1/2" Depth
- Infill Thicknesses:
 - 1" Thick Infill Standard
 - Glazing Adapters For 1/8" to 1-1/8" Infill
- Thermally broken design for energy performance
- Shear block construction prevents visible fasteners
- Horizontal members use a Shear Block to method to fasten horizontal and vertical members
- Painted Finishes in Standard and Custom Colors to AAMA 2605 Superior Performance Coating.
- Optional Features:
 - Reinforce Mullions for greater Spans;
 - Rainscreen Panel and Back Pan;
 - Optional deep profile or Bullnose covers;
 - Heavy Weight Mullions;
- Product Applications:
 - Low or Mid-Rise Buildings
 - Health Care Facilities
 - Educational Facilities
 - Retail
 - Parking Garages



Standard Details

